

Machined
Ra 0,7 (✓)
a, b, c
⊙ 0,15 a b c

ISOMETRIC
PERSPECTIVE
(1 : 3)

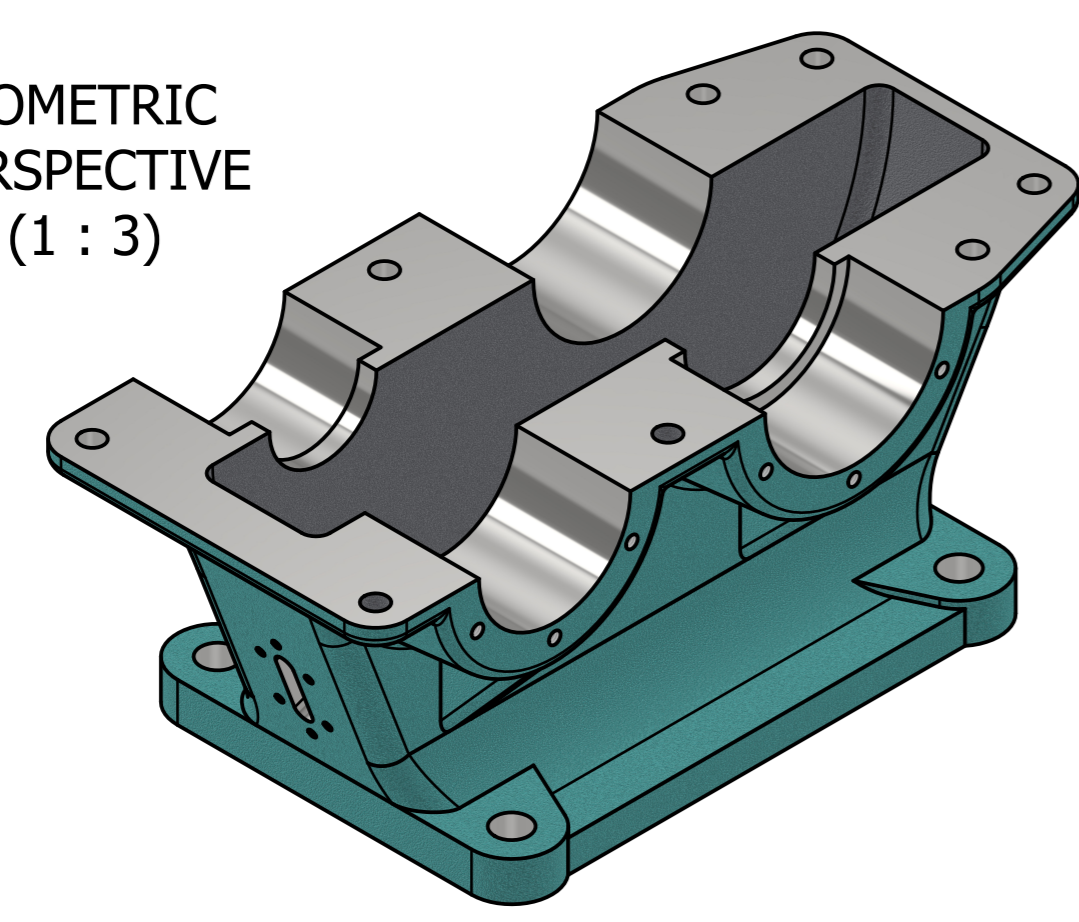

Note: General tolerances not specified follow ISO 2768-f.

Material: EN-GJL-250	Mass: 26,2 kg	Finishing: Topcoat PU	Brute Dimensions: N/A (Casting)		
Designer & Engineer: Leandro Neves		Dihedral: 	Escale: 1 : 4	Size: A2	Data: 16/02/2026
Component: Lower Housing			Quantity: 01		LEANDRO NEVES
Code of sheet: SRLN-DWG-SSEM-001	Project: SRLN	Revision: v00	Sheet: 2/12		