

Machined
 a, b, c $\sqrt{\text{Ra } 0,7}$ (✓)
 ◎ 0,15 a b c

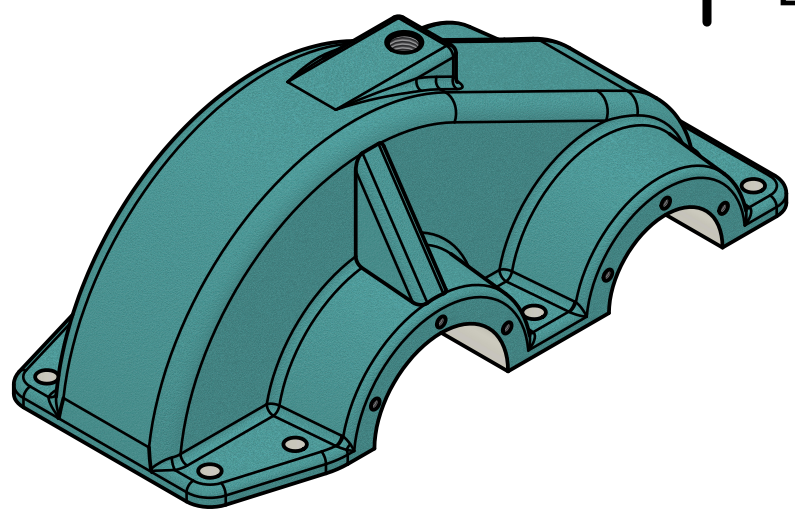
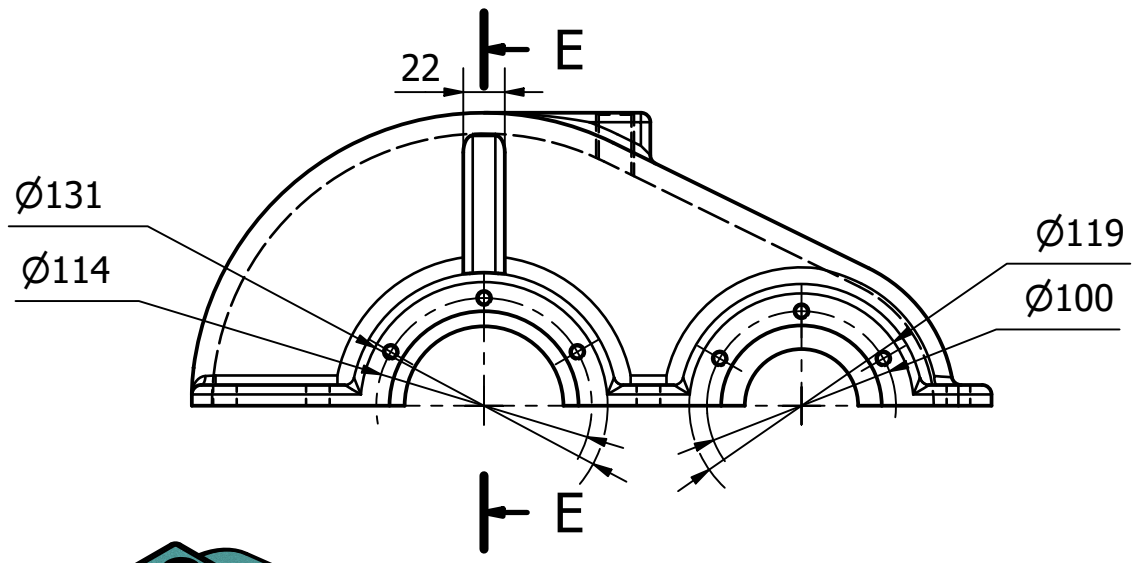
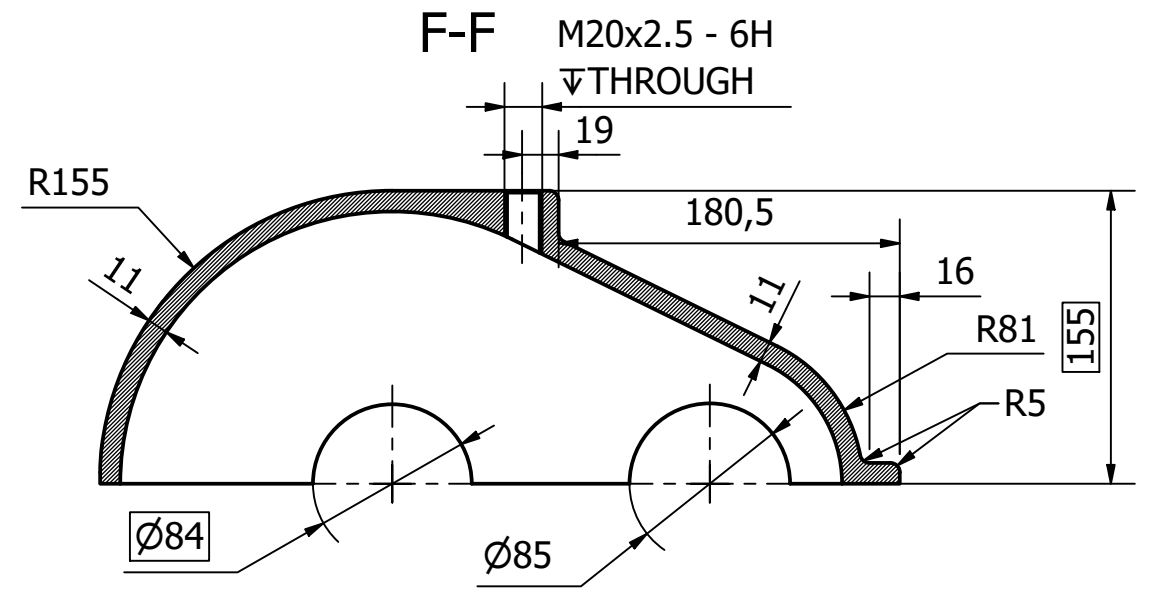

Note: General tolerances not specified follow ISO 2768-f.

Material: EN-GJL-250	Mass: 17,1 kg	Finishing: Topcoat PU	Brute Dimensions: N/A (Casting)		
Designer & Engineer: Leandro Neves		Dihedral: 	Escale: 1 : 4	Size: A3	Data: 16/02/2026
Component: Upper Housing			Quantity: 01	LEANDRO NEVES	
Code of sheet: SRLN-DWG-SSEM-002	Project: SRLN	Revision: v00	Sheet: 3/12		